



Patent #6,253,416 and other patents pending
F902SPS, F902SPH, F1302SPH, F1802SPV
BILLY GOAT FORCE BLOWER
Owner's Manual

Accessories

HOLD DOWN KIT <i>To secure blower for transportation on trailer floors.</i>

P/N 440120

SOLID FRONT TIRE <i>Solid flat-free front tire.</i>

P/N 440279

PARKING BRAKE <i>Effective and Easy to use to prevent blower from rolling.</i>

P/N 440140

CASTER KIT <i>For greater maneuverability on hard surfaces.</i>

P/N 440293



CONTENTS

SPECIFICATIONS AND SOUND/VIBRATION	3
INSTRUCTION LABELS	4
PACKING CHECKLIST	5
ASSEMBLY	6
OPERATION	7-8
MAINTENANCE	9
TROUBLESHOOTING	10
ILLUSTRATED PARTS LIST	11
PARTS LIST	12

Go to <http://www.billygoat.com> for French-Canadian translations of the product manuals.

Visitez <http://www.billygoat.com> pour la version canadienne-française des manuels de produits



Specifications

	F902SPS	F902SPH	F1302SPH	F1802SPV
Engine: HP	9.0 HP (6.6kW)	9.0 HP (6.6kW)	13.0 HP (9.6kW)	18 HP (13.42kW)
Engine: Model	EX270D50021	GX270K1QA2	GX390K1QAA2	3564420224E9
Engine: Type	SUBARU OHC	HONDA OHV	HONDA OHV	B & S VANGUARD
Engine: Fuel Capacity	6.4 qt. (6.1L)	6.3 qt. (6.0L)	6.5 qt. (6.1L)	9 qt. (8.52L)
Engine: Oil Capacity	1.05 qt. (1.0L)	1.16 qt. (1.1L)	1.16 qt. (1.1L)	1.75 qt. (1.66L)
Total Unit Weight:	141 # (64 Kg)	152 # (68.9 Kg)	167 # (75.7 Kg)	182 # (82.6 Kg)
Overall Length:	58"(1.43m)	58"(1.43m)	58"(1.43m)	58"(1.43m)
Overall Width	29.25" (0.74m)	29.25" (0.74m)	29.25" (0.74m)	29.25" (0.74m)
Overall Height	45" (1.14m)	45" (1.14m)	45" (1.14m)	45" (1.14m)
Max operating angle	20°	20°	20°	25°
In compliance with 2000/14/EEC standards	107dB(a) @3340 rpm	109dB(a) @ 3660 rpm	110dB(a) @ 3640 rpm	117dB(a)
Sound at Operator's ears	87dB(a) @ 3340 rpm	89dB(a) @ 3660 rpm	90dB(a) @ 3640 rpm	97dB(a)
Vibration at operator position	.96 g (9.44 m/s ²)	1.05 g (10.30 m/s ²)	.81 g (7.96 m/s ²)	1.2 g (11.9 m/s ²)

SOUND



SOUND LEVEL 97 Db(a) at Operators Position

Sound tests were conducted in accordance with 2000/14/EC, as well as ISO 11094, and were performed on 12-12-2006 under the conditions listed below.

Sound power level listed is the highest value for any model covered in this manual. Please refer to serial plate on the unit for the sound power level for your model.

General Conditions:	Sunny
Temperature:	40.4°F (4.7°C)
Wind Speed:	6.1 mph (9.9kph)
Wind Direction:	Southwest
Humidity:	93.6%
Barometric Pressure:	30Hg (101.85kpa)

VIBRATION DATA

VIBRATION LEVEL 1.2g (11.9m/s²)

Vibration levels at the operator's handles were measured in the vertical, lateral and longitudinal directions using calibrated vibration test equipment. Tests were performed on 12-13-2006 under the conditions listed below.

General Conditions:	Sunny
Temperature:	57.2°F (14.3°C)
Wind Speed:	11.8 mph (19.1kph)
Wind Direction:	South
Humidity:	46.4%
Barometric Pressure:	30.1Hg (101.96kpa)



INSTRUCTION LABELS

The labels shown below were installed on your BILLY GOAT[®] FORCE Blower. If any labels are damaged or missing, replace them before operating this equipment. Item numbers from the Illustrated Parts List and part numbers are provided for convenience in ordering replacement labels. The correct position for each label may be determined by referring to the Figure and Item numbers shown.



LABEL SPARK ARRESTOR
P/N 100252



LABEL READ OWNERS MANUAL
ITEM #44 P/N890301

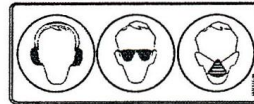

LABEL EAR EYE BREATHING
ITEM# 45 P/N890254



DANGER FLYING DEBRIS
ITEM # 46 P/N 810736

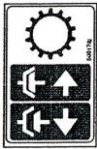

LABEL CLUTCH ENGAGE
P/N 500176



LABEL EXPLOSIVE FUEL
ITEM # 43 P/N 400268



LABEL OIL CHAIN
ITEM #119 P/N 830502



LABEL THROTTLE CONTROL
ITEM # 42 P/N 810656

ENGINE LABELS

HONDA



READ OWNERS MANUAL BEFORE OPERATION
LIRE LE MANUEL UTILISATEUR AVANT USAGE
VOR INBETRIEBNAHME UNBEDINGT BEDIENTUNGSANLEITUNG
NO UTILIZAR SINANTES NO HABERMANUAL

HONDA MOTOR CO., LTD. MADE IN JAPAN

OIL ALERT
WHEN OIL LEVEL LOW,
ENGINE STOPS IMMEDIATELY.

SUBARU



	Read the owner's manual.		
	Stay clear of the hot surface.		
	Exhaust gas is poisonous. Do not operate in an unventilated area.		
	Stop the engine before refueling.		
	Fire, open flame and smoking prohibited.		
	On (Run)	+	Plus; Positive polarity
○	Off (Stop)	⊞	Battery
	Engine oil		Engine start (Electric start)
	Add oil		

BRIGGS AND STRATTON VANGUARD

ENGINE MAINTENANCE

1. CHECK OIL LEVEL	8 HOURS
2. CHECK & CLEAN AIR CLEANER	25 HOURS
3. CHANGE OIL	50 HOURS
4. REPLACE OIL FILTER	100 HOURS
5. CLEAN COOLING FINS	100 HOURS

See Operating and Maintenance Instructions

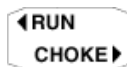
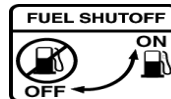



PACKING CHECKLIST

These items should be included in your carton. If any of these parts are missing, contact your dealer. Your BILLY GOAT® *FORCE Blower* was shipped in one carton, completely assembled except for the Upper Handle Assembly and Front Diverter. Mounting hardware for the Upper Handle Assembly can be found in the parts bag.



READ all safety instructions before assembling unit.

TAKE CAUTION when removing the unit from the box as the Handle Assembly is attached to the unit by cables.



PUT OIL IN ENGINE BEFORE STARTING

PARTS BAG & LITERATURE ASSY

Warranty card P/N- 400972, Owner's Manual P/N-440314, General Safety and Warnings Manual P/N-100294. Declaration of Conformity P/N-440022. Handle Hardware-Items #10. #11. #74. #36. and #123

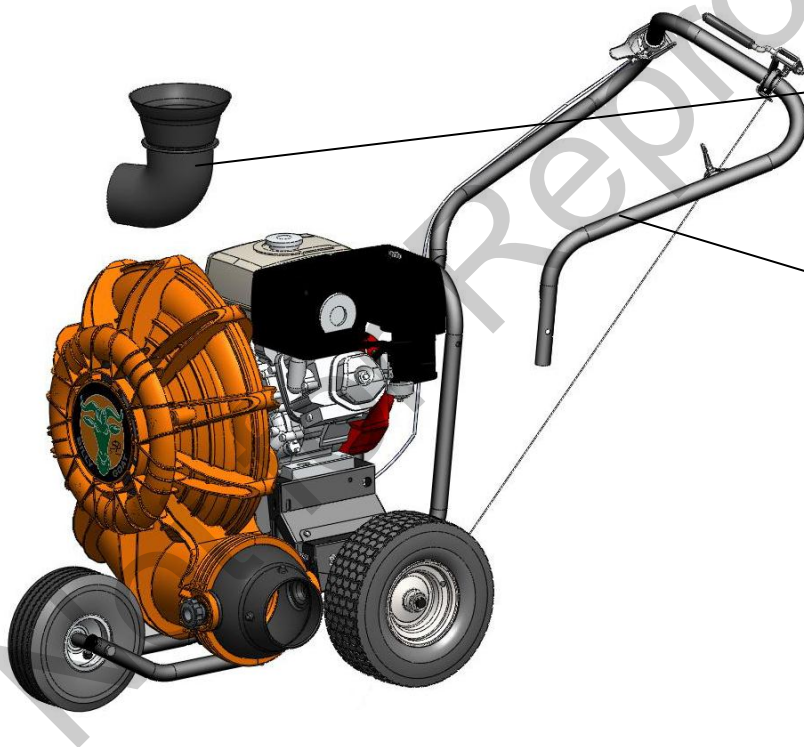

Boxing Parts Checklist

- Front Air Diverter
(For F902S, F902H, and F1302H models only)
Item#38
F9 MODELS P/N-440045-4
F13 MODELS P/N-440045-5
- Handle Upper Assembly
Item #30 P/N-440035
- Parts Bag & Literature Assy
P/N-440267
- Honda 9 or 13 hp
- Subaru 9 hp
- B & S Vanguard 18 hp

ASSEMBLY

1. Follow the steps in figures A and B, then securely tighten all hardware shown.
2. Connect spark plug wire.

Figure A

The hardware for attaching the upper handle to the lower is in the parts bag. Install upper handle (item 30), to preassembled lower handle (item 28) by sliding the upper over and down the outside of the lower handle. Using the bolts (items #36 and 123), washers (item #10) & lock nut (item #11) to install upper handle to lower handle. **Note:** The Pigtail bolt should go on the side that the pull start is on and the open end should be facing down. Finish installing the other side of the upper handle assembly using screw and lock nut provided.

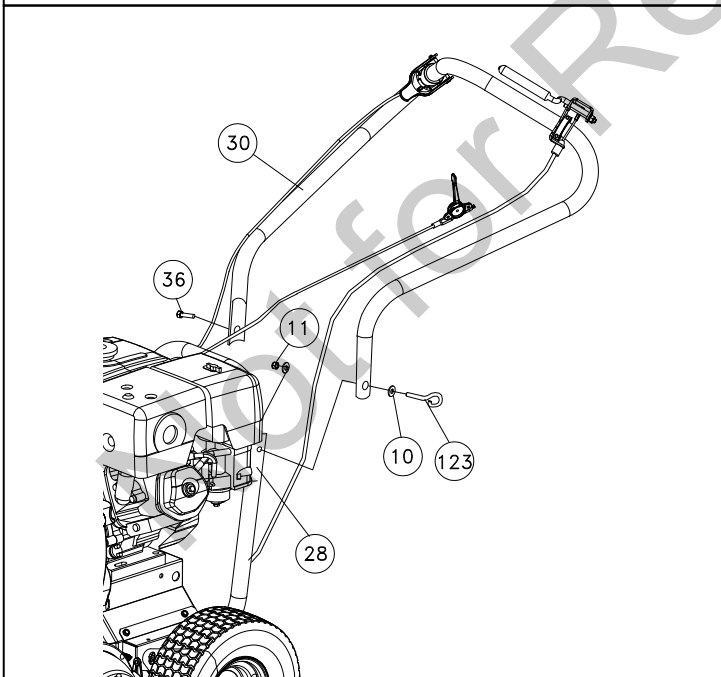
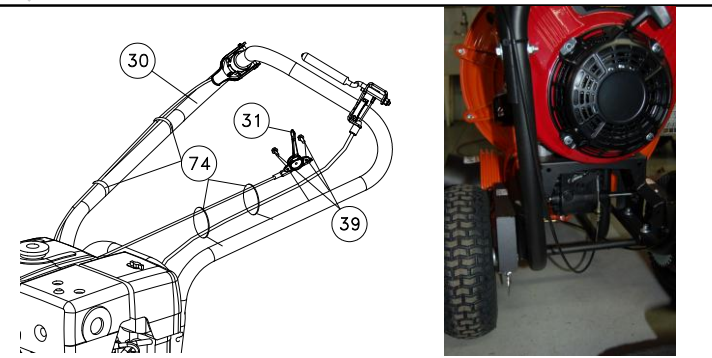

Figure B

The throttle control will be attached to the throttle arm on the engine and wrapped around the engine for shipping. Unwrap and secure throttle control (item #31) to upper handle with screws (item #39). Screws will already be mounted in handle, simply remove and use to mount the throttle control. Secure the throttle cable and clutch cable with two Ty-wraps. The Aim-and-Shoot™ is not attached, you will need to unroll the cable and attach the ball end to the lever and seat the cable end into the hole on the saddle clamp, with the cable running through the slot. The Clutch cable will also be wrapped up under the machine. Route the cable under the axle and attach it by removing the hitch pin and clevis pin and attaching it to the clutch control lever. After it is attached pull on the cable and slide it into the hole on the bracket so that it clicks into place. To keep the cable from being damaged use three ty-wraps (item 74) to secure it to the handle as shown making sure that the cable is not rubbing against the tire. **Note:** the cable should be seated properly in the saddle and should follow the contours of the handle.



Good routing

Bad routing



Two 1/2" open ended wrenches



One 5/16 open ended wrench



OPERATION

DRIVE LEVER:

To engage the clutch for forward motion, simply hold down the clutch lever with your left hand while the engine is running, this will cause the drive to engage and the machine will proceed to move forward. ⚠ Caution: It is not recommended to “feather” the drive. The drive lever should be either fully engaged or fully disengaged. Failure to do so can cause premature failure of the cone clutch in the transmission. This type of failure will void the manufacturer’s warranty.

BLOWING OPERATION

Your Billy Goat Force blower is equipped with an air director cone and the patented Aim-N-Shoot™ control lever to allow the operator to direct the air stream up or down as required to assist in moving debris. This feature is extremely useful when debris has piled up to the point that it cannot be blown any farther. The air stream can be directed upward to blow the top of the debris pile over and allow the operator to continue moving more debris farther.

ADJUSTING AIR DIRECTOR

To adjust air direction, squeeze Aim-N-Shoot™ control lever. When you want to blow debris at the same angle for an extended period, choose a suitable position and use the finger controlled push button lock to lock the cone in position. For operations that do not require the use of the Aim-N-Shoot™ feature the manual adjustment knob, pictured below, can be used to permanently lock the cone into position. ⚠ **CAUTION:** Be sure to release the knob when returning to using the Aim-N-Shoot™.

⚠ **DO NOT** position director cone to where it will blow debris towards people, vehicles or other objects in vicinity. Flying debris may damage, harm, or cause injury to people or objects in air flow range.

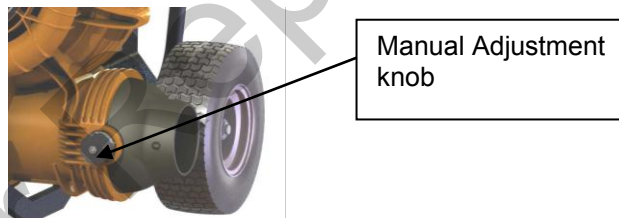

FRONT DIVERTER POSITIONING (F9 and F13 models only)

The removable front diverter adapter can be slipped inside the cone to direct the air stream forward. **First turn off engine**, and then simply collapse and fold in the larger opening of the diverter and slide inside the cone and allow it to expand. Then position to the desired angle by rotating the diverter. This option is extremely useful for cleaning out long cracks in pavement or for cleaning under bushes, building overhangs or along curbs.

⚠ **WARNING:** Unit will be more difficult to control due to the air exiting the unit. Keep hands on the unit at all times when using the front diverter. Please note that the Aim-N-Shoot™ feature will not function when the Front Diverter is installed

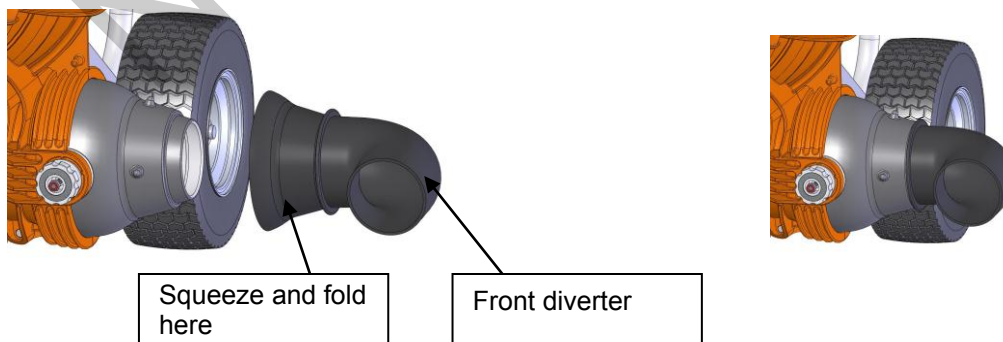



MAINTENANCE

Periodic maintenance should be performed at the following intervals:

Maintenance Operation	Every Use	Daily or Every 5 Hours	Every 25 Hours	Every 50 Hours	Every 100-150 Hours
Inspect for worn or damaged parts.	•				
Check for excessive vibration		•			
Check belt/chain tightness	•				
Oil drive chain		•			
Inspect Impeller for cracks or damage					•
Inspect for loose parts.		•			

IMPELLER REMOVAL

1. Wait for engine to cool and disconnect spark plug.
2. Remove housing front cover, by removing (11) bolts and nuts, items #13 & #14, around outside of front cover.
3. Remove impeller bolt (item #35), lock washer (item #71) and washer (item #34).
4. DO NOT pry on impeller. Pull on center hub area only of impeller. *Using a penetrating oil can help loosen a stuck impeller.*
5. Reinstall new impeller in reverse order of removal.
6. Tighten impeller bolt. Torque impeller bolt (see parts list on page 11 for proper impeller bolt torque specifications).

TIRE AIR PRESSURE

Check at regular intervals and maintain.

Front Tires - 24 Psi (165 kPa).

Rear Tires - 20 Psi (137 kPa).

BELT TENSION ADJUSTMENT

DO NOT ADJUST WHILE THE MACHINE IS RUNNING!

1. Wait for engine to cool and disconnect spark plug.
2. Loosen the nut (item 92) on the Idler pulley (item 93) but do not remove it. This should allow the pulley to slide left or right. Once the pulley is at the proper distance to apply tension to the belt tighten the nut. **Note:** Do not place too much tension on the belt, as it will cause premature failure.
3. Reattach the spark plug.

BELT REPLACEMENT

1. Wait for engine to cool and disconnect spark plug.
2. Follow the Impeller removal steps (2-5 on page 12).
3. Remove the four bolts (item 8) holding the back plate (item 4) to the back housing (item 6).
4. Loosen the nut on the idler pulley and slide it to the right to relieve tension on the belt.
5. Slip the belt (item 86) off the engine pulley and the transmission.
6. Replace the belt with a new one and slide the Idler pulley to put proper tension on the belt. **Note:** Do not place too much tension on the belt, as it will cause premature failure.
7. Reassemble the machine in reverse order. **Note:** You will need to replace the Impeller bolt and torque to the proper specifications see page 11. **DO NOT** use the old impeller bolt.
8. Reconnect spark plug wire.

Idler Pulley

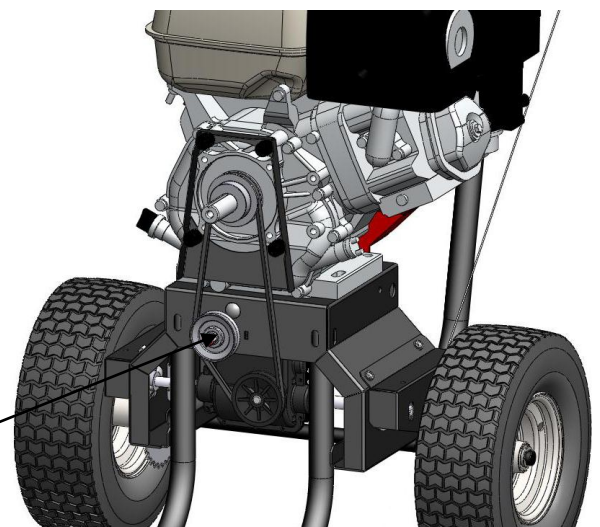

DRIVE CHAIN REPLACEMENT

1. Wait for engine to cool and disconnect spark plug.
2. Place a block of wood, or another object that will support and steady the unit under the axle on the side of the machine you will be working on.
3. Remove the two screws (item 103) holding the chain guard (item 104) and then remove the chain guard.
4. Loosen the two nuts (item 98) holding the bearing (item 97).
5. Remove the retaining ring holding the wheel on and then slide the wheel off.
6. Replace the chain (item 105). Remove the old chain by walking it off the sprockets.
7. Position the bearing so that it applies the proper tension to the chain and tighten the nuts holding the bearing **Note: DO NOT** over tighten the chain, as this will cause premature failure. Likewise if the chain is too loose it will come off when the drive is engaged.
8. Reassemble the machine using steps 1-4 in reverse order.

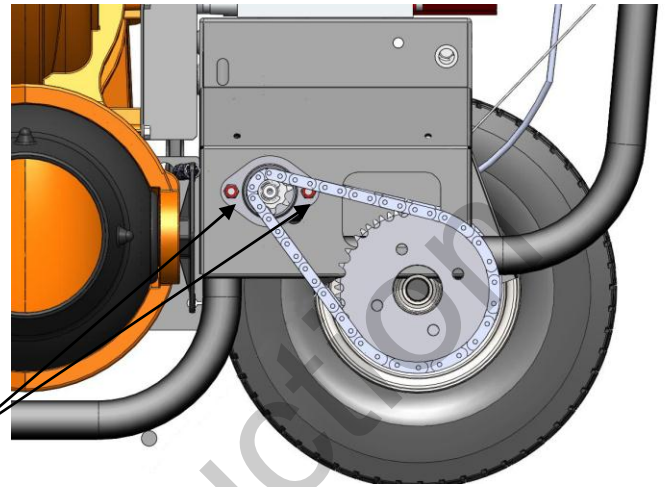

Loosen these nuts

CLUTCH CABLE ADJUSTMENT

1. With the machine off, loosen the two nuts on the end of the clutch cable (item 111) going in to the transmission.
2. By moving the position up or down on the threads it will change the tension on the clutch lever (item 113). **Note:** Do not position it too high on the threads as this could cause the drive not to engage. Likewise, if it is placed too low the drive may stay permanently engaged. The optimum setting is to remove any slack in the clutch cable when disengaged. The travel of the clutch control will apply the correct spring force on the cone clutch. Once the desired position is in place tighten the nuts securely.
3. Start the machine and check the operation. If the drive cable is not engaging properly, shut the machine off and reposition the nuts on the cable to tighten the drive cable.

TROUBLESHOOTING

Problem	Possible Cause	Solution
Abnormal vibration.	<ul style="list-style-type: none"> Loose or out of balance impeller. Debris in impeller. Loose engine. 	<ul style="list-style-type: none"> Check impeller and replace if required. Clear debris with compressed air or a backpack blower (see below pictures).* Check engine.
Engine will not start.	<ul style="list-style-type: none"> Engine not in full choke position. Out of gasoline or bad, old gasoline. Spark Plug wire disconnected. Gas valve off. Dirty air cleaner. 	<ul style="list-style-type: none"> Check choke position. Check gasoline. Connect spark plug wire. Turn on gas valve. Clean or replace air cleaner. Contact a qualified service person.
Engine is locked, will not pull over.	<ul style="list-style-type: none"> Engine problem. 	<ul style="list-style-type: none"> Contact an engine servicing dealer for engine problems.
Aim-N-Shoot™ lever sticking	<ul style="list-style-type: none"> Debris stuck around cone Cone adjustment knob too tight Adaptor mount nut (item 38) too tight 	<ul style="list-style-type: none"> Clean debris Apply silicone based lubricant to pivot points Loosen manual adjustment knob Loosen nut
No self propelling	<ul style="list-style-type: none"> Drive lever not engaged Drive belt worn or broken Drive chain off the sprockets Drive cable is out of adjustment 	<ul style="list-style-type: none"> Engage drive lever Check drive belt Check drive chain Check drive cable (see page 13)
Self Propelled drive will not release	<ul style="list-style-type: none"> Improper drive cable adjustment, or cable is kinked 	<ul style="list-style-type: none"> Check the drive cable (see page 13)
Noisy or broken chain	<ul style="list-style-type: none"> No chain or lubrication Chain tension 	<ul style="list-style-type: none"> Lubricate chain Check drive chain (see page 13)

*Using compressed air, or a Backpack blower, you can loosen or free debris easily from the impeller and housing, which can cause wear and tear on the machine. You can manually remove debris by taking off the front housing.
 Note: Always disconnect the spark plug when servicing.



ILLUSTRATED PARTS LIST

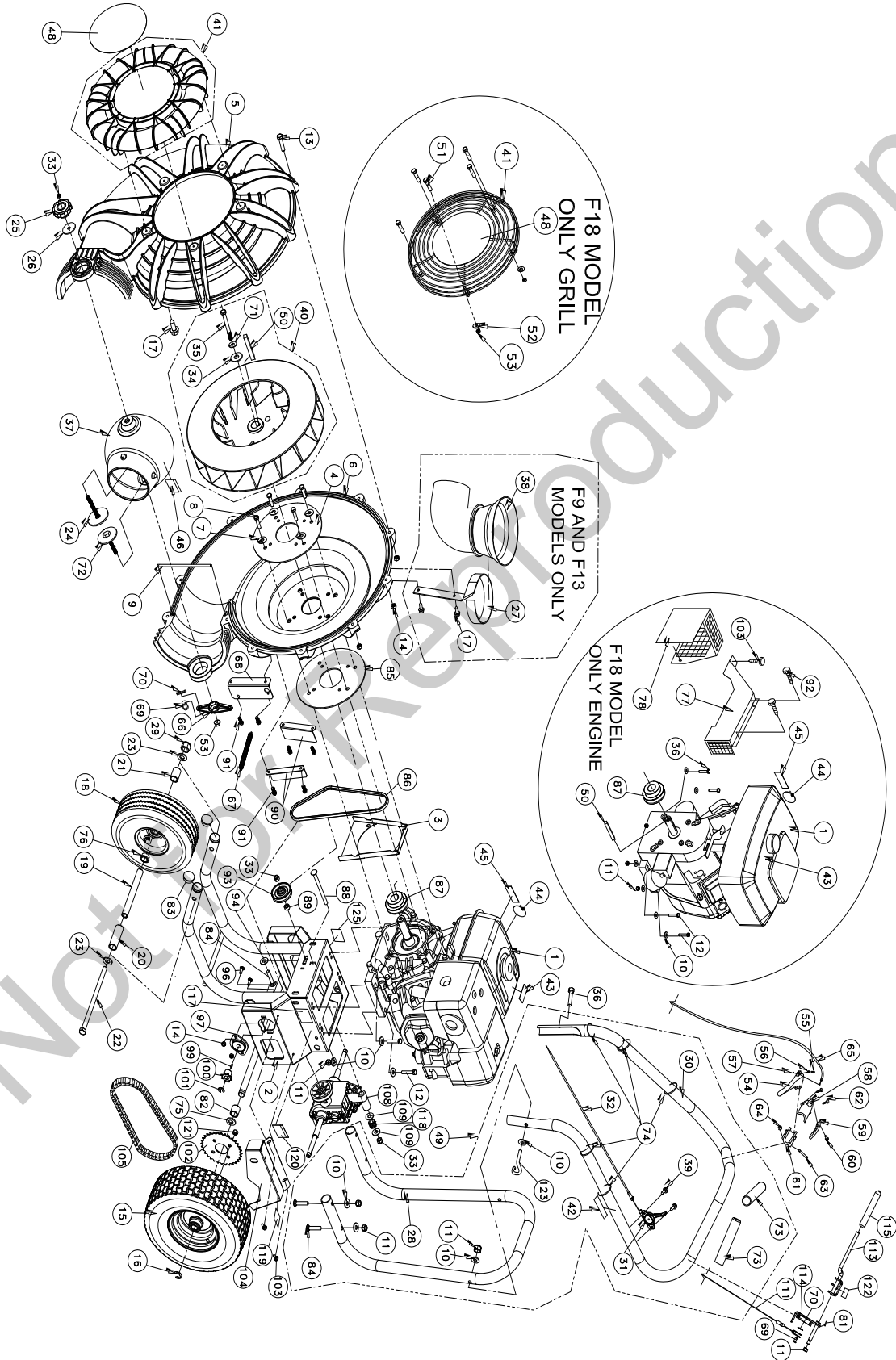



PARTS LIST

ITEM NO.	DESCRIPTION	F1302SPH		F902SPH		F902SPS		F1802SPV	
		PART NUMBER	QTY.	PART NUMBER	QTY.	PART NUMBER	QTY.	PART NUMBER	QTY.
1	ENGINE 13 HP HONDA GX390	440018	1	-	-	-	-	-	-
	ENGINE 9 HP HONDA GX270	-	-	430287	1	-	-	-	-
	ENGINE 9 HP HORZ SUBARU OHC	-	-	-	-	430413	1	-	-
	ENGINE 18 VANGUARD	-	-	-	-	-	-	812240	1
2	BASE ENGINE WA FSP	440244-S	1	440244-S	1	440244-S	1	440244-S	1
3	GUARD BELT UPPER FSP	440209	1	440209	1	440209	1	440209	1
4	PLATE REINFORCE HOUSING	440010-P	1	440010-P	1	440010-P	1	440010-P	1
5	HOUSING FRONT MOLDED	440023	1	440023	1	440023	1	440023	1
6	HOUSING BACK MOLDED	440024	1	440024	1	440024	1	440024	1
7	WASHER LOCK 3/8 S/T MED	8177012	4	8177013	5	8177013	5	8177013	4
8	SCREW CAP 3/8-16X 2 ZP	8041054	4	8041054	4	8041054	4	8041054	4
9	ROD HAND STOP	440057	1	440057	1	440057	1	440057	1
10	WASHER 5/16 FLATWASHER Z/P	8171003	14	8171003	14	8171003	14	8171003	14
11	NYLON INSERT LOCKNUT 5/16-18	8160002	11	8160002	11	8160002	11	8160002	11
12	SCREWCAP 5/16-18 X 1.75 ZP	8041031	4	8041031	4	8041031	4	8041031	2
13	SCREWCAP 1/4-20 x 1 1/2	8041008	11	8041008	11	8041008	11	8041008	11
14	NUT FLANGE 1/4-20	900455	15	900455	15	900455	15	900455	15
15	WHEEL & TIRE 13" X 5" PNEUMATIC SPROCK	440219	2	440219	2	440219	2	440219	2
16	RING RETAINING 3/4	850230	2	850230	2	850230	2	850230	2
17	SCREW SM 1/4" X 3/4" TYPE AB HX WF	8122082	7	8122082	7	8122082	7	-	-
18	WHEEL ASSY 10 " PNEUMATIC	400295	1	400295	1	400295	1	400295	1
19	SPACER FRONT AXLE	440220	1	440220	1	440220	1	440220	1
20	SPACER LH WHEEL FRONT	440224	1	440224	1	440224	1	440224	1
21	SPACER RH WHEEL FRONT	440221	1	440221	1	440221	1	440221	1
22	SCREWCAP 1/2-13 x 9 1/2"	8041240	1	8041240	1	8041240	1	8041240	1
23	WASHER FLAT 1/2" SAE	8172011	2	8172011	2	8172011	2	8172011	2
24	WASHER W/BOLT WA	440075	1	440075	1	440075	1	440075	1
25	KNOB 3/8-16 SOLID HUB	811230	1	811230	1	811230	1	811230	1
26	WASHER 2.25 OD x .515 ID x .134 ZP	610308-P	1	610308-P	1	610308-P	1	610308-P	1
27	BRACKET HOLDER WA	440240	1	440240	1	440240	1	-	-
28	HANDLE LOWER	440034	1	440034	1	440034	1	440034	1
29	NYLON INSERT LOCKNUT 1/2-13LT WT TH ZP	8161044	1	8161044	1	8161044	1	8161044	1
30	HANDLE UPPER	440035	1	440035	1	440035	1	440035	1
31	CONTROL THROTTLE	440013	1	440013	1	440013	1	440013	1
32	CABLE THROTTLE CONTROL	440014	1	440014	1	440014	1	440178	1
33	NUT LOCK 3/8-16 LT WT THIN ZP	8161042	3	8161042	3	8161042	3	8161042	3
34	WASHER 1.5 O.D.X 0.45 I.D. X 0.5	440176	1	440176	1	440176	1	440176	1
35	SCREWCAP 3/8-24 X 3.5 GR. 8 (38 +/-2 ft-lbs.)	440151	1	-	-	-	-	-	-
	SCREWCAP 7/16-20 X 3.5 GR.8 (60 +/-2 ft-lbs)	-	-	440150	1	440150	1	-	-
	SCREWCAP 3/8-24 X 4 GR.8 (38 +/-2 ft-lbs)	-	-	-	-	-	-	8042062	1
36	SCREWCAP 5/16"-18 X 2" ZP	8041032	1	8041032	1	8041032	1	8041032	2
37	DIRECTOR CONE 5"	440044-S	1	-	-	-	-	-	-
	DIRECTOR CONE 4"	-	-	440046-S	1	440046-S	1	-	-
	DIRECTOR CONE 6"	-	-	-	-	-	-	440170-S	1
38	DIVERTOR FRONT	440045-5	1	440045-4	1	440045-4	1	-	-
39	SCREW SM #10-24X1/2" DRILL POINT	8122064	2	8122064	2	8122064	2	8122064	2
40	IMPELLER ASSEMBLY 17"	440236	1	440236	1	440236	1	-	-
	IMPELLER SERVICE ASSY FORCE 18HP	-	-	-	-	-	-	440162	1
41	GRILL FRONT BLOWER	440067-1-S	1	440067-1-S	1	440067-1-S	1	440171-S	1
42	LABEL THROTTLE CONTROL	810656	1	810656	1	810656	1	810656	1
43	LABEL FUEL EN/SP	-	-	-	-	100261	1	100261	1
44	LABEL READ	890301	1	890301	1	890301	1	890301	1
45	LABEL EAR EYE BREATHING	890254	1	890254	1	890254	1	890254	1
46	LABEL DANGER FLYING DEBRIS	810736	1	810736	1	810736	1	810736	1
48	LABEL FORCE	440269	1	440269	1	440269	1	440269	1
49	HANDLE ASSY	440104	1	440104	1	440104	1	440104	1
50	KEY 1/4" SQ x 3 1/4	9201128	1	9201128	1	9201128	1	-	-
	KEY 1/4" SQ x 2 3/4	-	-	-	-	-	-	9201130	1
51	SCREWCAP 1/4-20 X 1" HCS ZP	-	-	-	-	-	-	8041006	5
52	WASHER FLAT 1/4	-	-	-	-	-	-	8171002	5
53	NUT LOCK 1/4"-20 HEX ZP	8160001	1	8160001	1	8160001	1	8160001	6
54	HANDLE DIVERTER FORCE	440119	1	440119	1	440119	1	440119	1
55	PIN LATCH DIVERTER	440118	1	440118	1	440118	1	440118	1
56	SPRING COMPRESSION 0.281 X 0.88	440129	1	440129	1	440129	1	440129	1
57	RING RETAINING .122 DIA	440125	1	440125	1	440125	1	440125	1
58	SADDLE LOWER DIVERTER	440115	1	440115	1	440115	1	440115	1
59	PLATE LOCK DIVERTER	440116	1	440116	1	440116	1	440116	1
60	SCREW PLASTITE #6-19 X 5/8"	440126	1	440126	1	440126	1	440126	1
61	SADDLE UPPER DIVERTER	440114	1	440114	1	440114	1	440114	1
62	SCREW PLASTITE #10-14 X 1"	440132	2	440132	2	440132	2	440132	2
63	PIN PIVOT DIVERTER CONTROL	440123	1	440123	1	440123	1	440123	1
64	RING RETAINING 5/16	430327	1	430327	1	430327	1	430327	1



PARTS LIST

ITEM NO.	DESCRIPTION	F1302SPH		F902SPH		F902SPS		F1802SPV	
		PART NUMBER	QTY.	PART NUMBER	QTY.	PART NUMBER	QTY.	PART NUMBER	QTY.
65	CABLE ASSY	440117	1	440117	1	440117	1	440117	1
66	DIVERTER PIVOT ADAPTOR	440121	1	440121	1	440121	1	440121	1
67	SPRING EXTENSION 0.468 X 5.25	440130	1	440130	1	440130	1	440130	1
68	BRACKET DIVERTER FORCE	440212	1	440212	1	440212	1	440212	1
69	PIN CLEVIS 1/4 X 3/4	440124	2	440124	2	440124	2	440124	2
70	HITCH PIN CLIP .051 X 3/4"	440193	2	440193	2	440193	2	440193	2
71	WASHER LOCK 3/8 S/T MED	8177012	1	-	-	-	-	8177012	1
	WASHER LOCK 7/16 S/T MED	-	-	8177013	1	8177013	1	-	-
72	ADAPTOR MOUNT WA	440122	1	440122	1	440122	1	440122	1
73	GRIP 1-1/4" ID x 9.5" LONG	440146	2	440146	2	440146	2	440146	2
74	TY-WRAP	900407	5	900407	5	900407	5	900407	5
75	WASHER .765 ID X 1.25 OD X0.6"	850238	2	850238	2	850238	2	850238	2
76	FORCE WHEEL BEARING .751 ID	440055	2	440055	2	440055	2	440055	2
77	GUARD MANIFOLD	-	-	-	-	-	-	812243	1
78	GUARD MUFFLER	-	-	-	-	-	-	812242	1
81	ROLL PIN	8195096	1	8195096	1	8195096	1	8195096	1
82	SPACER REAR WHEEL SP	440225	2	440225	2	440225	2	440225	2
83	PLUG	791056	2	791056	2	791056	2	791056	2
84	CARRIAGE BOLT 3/8"-16 X 1 3/4" ZP	8024061	5	8024061	5	8024061	5	8024061	5
85	SPACER ENGINE FACE	440174	1	440174	1	440174	1	440174	1
86	BELT 3L29	440215	1	440215	1	440215	1	440215	1
87	SPACER HUB 1" ID X 1.25" W/PULLEY	440213	1	440213	1	440213	1	-	-
	SPACER HUB 1" ID X 1.25" W/PULLEY FSP18	-	-	-	-	-	-	440214	1
88	CARRIAGE BOLT 3/8-16 X 5" ZP	8024161	1	8024161	1	8024161	1	8024161	1
89	TUBE SPACER .625" OD X .357 LONG	440228	1	440228	1	440228	1	440228	1
90	GUARD BELT LOWER FSP	440210	2	440210	2	440210	2	440210	2
91	SCREW PLASTITE 1/4-10 X 3/4 HWH ZP	840082	6	840082	6	840082	6	840082	6
92	BOLT 1/4"-20 X 1/2" SER FLANGE	-	-	-	-	-	-	812381	2
93	PULLER V IDLER 2.5	510137	1	510137	1	510137	1	510137	1
94	WASHER 1.00" OD X .380 SQ HOLE	440227	1	440227	1	440227	1	440227	1
96	CARRIAGE BOLT 1/4"-20 X 3/4"	8024021	4	8024021	4	8024021	4	8024021	4
97	BEARING 1/2" STEEL PRESSED HOUSING	891025	2	891025	2	891025	2	891025	2
99	KEY WOODRUFF 1/8" X 1/2"	510180	2	510180	2	510180	2	510180	2
100	SPROCKET 8 TOOTH	891022	2	891022	2	891022	2	891022	2
101	RETAINING RING 1/2"	350146	2	350146	2	350146	2	350146	2
102	SPROCKET 32T #43 1.594 BORE	440218	2	440218	2	440218	2	440218	2
103	SCREW SELF TAP 1/4"-20 X 5/8"	890359	4	890359	4	890359	4	890359	6
104	CHAIN GUARD LH	440206-S	1	440206-S	1	440206-S	1	440206-S	1
	CHAIN GUARD RH	440207-S	1	440207-S	1	440207-S	1	440207-S	1
105	CHAIN #43X44 PITCHES	440217	2	440217	2	440217	2	440217	2
108	TRANS SINGLE SPEED W/CLUTCH	440216	1	440216	1	440216	1	440216	1
109	WASHER 3/8" SAE	8172009	2	8172009	2	8172009	2	8172009	2
111	CLUTCH CABLE FORCE SP	440243	1	440243	1	440243	1	440243	1
113	CLUTCH CONTROL ARM	440277	1	440277	1	440277	1	440277	1
114	CLUTCH CONTROL BRACKET	440245	1	440245	1	440245	1	440245	1
115	GRIP CLUTCH CONTROL FSP	440242	1	440242	1	440242	1	440242	1
117	SPARK ARRESTOR LABEL	100252	1	100252	1	100252	1	100252	1
118	SPRING LEVER GZ	610429	1	610429	1	610429	1	610429	1
119	LABEL OIL CHAIN	830502	2	830502	2	830502	2	830502	2
120	LABEL DANGER	900327	2	900327	2	900327	2	900327	2
121	NUT LOCK 5/16-24 SER HEX WSHR FLNG	440274	8	440274	8	440274	8	440274	8
122	LABEL CLUTCH DRIVE	500176	1	500176	1	500176	1	500176	1
123	EYEBOLT PIGTAIL 5/16"-18 X 1 1/4"	440280	1	440280	1	440280	1	440280	1
125	LABEL MADE IN U.S.A.	520116	1	520116	1	520116	1	520116	1